

Metal screed **betonwood**

Complete screed system on metal sheets or frames with high density BetonWood cement bonded particle boards

Beton  **Wood**

Complete insulating screed system with high performances



DESCRIPTION

Complete dry screed system on corrugated metal sheet or metal frames made in high performances Betonwood cement bonded particle boards. The BetonWood cement bonded particle boards with a density of 1350kg/m³ and a compression resistance equal to 9000 kPa, must be arranged in a staggered manner and screwed to the plate using NF60 screws type.

Maximum durability over time is guaranteed, with international ETA certification.

The stratigraphy can be characterized by a single layer or (for greater resistance needs) a double layer of BetonWood cement bonded particle boards, to be laid directly on the corrugated metal sheet or metal frame.

If you decide to use two layers of BetonWood cement bonded particle boards, is necessary to know that these must be laid crosswise, therefore the panels of the second layer must be positioned at 90° with respect to the panels of the first layer. The cement bonded particle boards must be fixed with NF60 screws near the corners and the center of each panel.

High acoustic performance, naturalness and simplicity of execution.

Advantages

- Excellent mechanical resistance
- Excellent compression strength
- Fire reaction class A2-fl-s1
- Extreme ease of installation

For more informations about the uses and the installation, our offices are ready to answer your questions on www.betonwood.com



STRATIGRAPHY

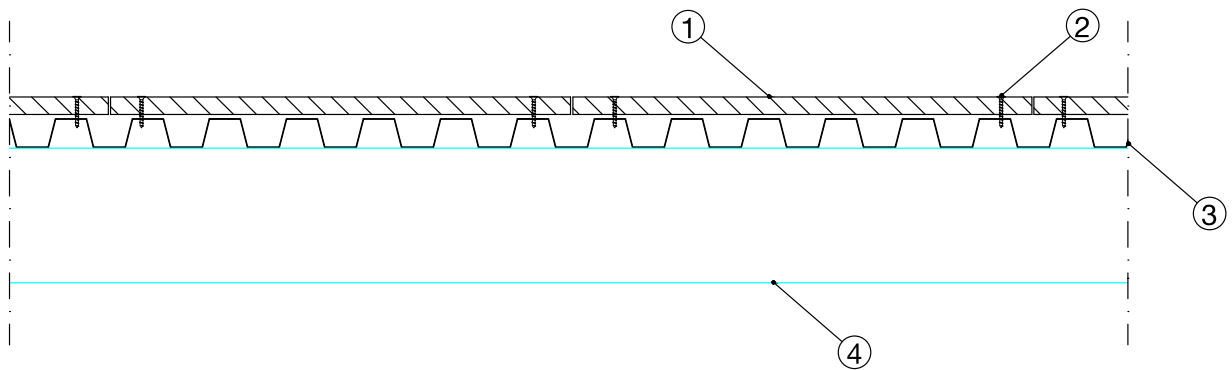

- 1 **Cement bonded particle boards BetonWood** made by Portland cement and wood fibers, has an high density of 1350 kg/m³ and an excellent compression resistance equal to 9.000,00 Kpa. These particular boards guarantee an optimal building solution to obtain high levels of thermal displacement, thanks to their high density which makes them also suitable for self-supporting dry screeds, radiant floors and stiffening structures.
- 2 **Screws type NF60** Self-drilling screws for fixing BetonWood N cement bonded particle boards directly to the insulating wood fiber panel Fibertherm Base. Number 9 screws are necessary for fixing each panel.
- 3 **Metal sheet** corrugated metal sheet
- 4 **Screed** metal frame



SYSTEM'S PRODUCTS



BetonWood The BetonWood cement bonded particle boards, with high density (1350 Kg/m³), made of Portland-type cement conglomerate and debarked Pine wood fiber. These panels have the following thermo-dynamics characteristics: thermal conductivity coefficient $\lambda = 0,26$ W/mK, specific heat $c = 1,88$ KJ/Kg K, coefficient of resistance to vapor penetration $\mu = 22,6$ and reaction to fire class A2-fl-s1, according to the standard EN 13501-1.

The panels size is ... mm and the thickness is ... mm.

The wood used in panel processing comes from forests controlled by FSC reforestation cycles and pressed with water and hydraulic binder (Portland cement) with high cold compression ratios.



Screws NF 60 The screw has a special anti-corrosion coating that guarantees a 1,000-hour salt spray resistance. Under-head with very sharp self-sinking fins for a perfect housing of the head flush with the slab. Drill bit that allows a perfect drilling capacity even on high sheet thicknesses.

BETONWOOD Srl

Head office :
Via Falcone e Borsellino, 58
I-50013 Campi Bisenzio (FI)

T: +39 055 8953144
F: +39 055 4640609

info@betonwood.com
www.betonwood.com

SBTWL - ST R.18.5

CERTIFICATIONS

Complete dry screed system on corrugated metal sheet with one or double layer of BetonWood cement bonded particle boards is produced with CE certified materials according to the regulations in force.



GENERAL SECURITY INSURANCE GUARANTEE
ON THE PRODUCT WITH CORRECT DOCUMENTED
INSTALLATION WITH PHOTOGRAPHS

Beton Wood

